

United States Air Force Reserve

Integrity - Service - Excellence

IMA Deployments



U.S. AIR FORCE



- **Seeking deployment opportunities**
- **IMA Volunteer process**
- **Statement of Understanding (SOU)**
- **Involuntary activations**
- **Deployment Waivers**
- **AEFI's**



Seeking Deployment Opportunities

- **Must be “GREEN-TO-GO”**
 - **Most deployments require passing fitness assessment; see location-specific Reporting Instructions**
 - **Must possess a 3-level in AFSC unless otherwise specified in the requirement**
 - **Work through detachment & Active component chain of command**
 - **Active Duty unit responsible for training & equipping**
 - **Note: UDM handles training dates, transportation, unit-funded equipment, UNIFORMS**
 - **RIO/IPR facilitates tasking the member in DCAPEs, requests mandays and initiates all order actions**
 - **Exception: Gaining MAJCOMs process manday requests for exercise participation**
-



IMA Volunteer Process

- **IRs may volunteer for deployment opportunities advertised through:**
 - **Volunteer Reserve System (VRS) – AFSC approved**
 - **AFRC Functional Area Managers (FAMs)**
 - **Assigned unit and/or the gaining command assuming they agree to provide associated mandays**
 - **0-6 and above need AFRC/CV Approval**
 - **Deployments must have a valid Unit Line Number (e.g. be an approved SecDef deployment requirement tracked in SIPR-based system)**
 - **Members must submit a Statement of Understanding (SOU) through supporting RIO Det**
-



U.S. AIR FORCE

Volunteer Reserve System (VRS)

- Access ARCNet through AF Portal
- Select "VRS" tab from the main ARCNet page

ARCNet Links

UPDATES - 26 April

ARCNet Docs
ARCNet CCB Charter
ARCNet Tasks (save to desktop)
ARCNet Newsletter Vol. 11 Iss. 3
ARCNet March Metrics

CBTs
ADL S/AFRC Unique CBTs
ANG CBTs
How to download ARCNet CBTs

HELP
ARCNet Duty Hours Guides
Update Readiness-NEW
What is ARCNet?
ARCNet Features
ADL S Data Interface
Webinar Training Calendar
How Are We Doing?

TRAINING SLIDES
AFR Ancillary Training
Training Details
Class Schedule
Duty Plan

AF PORTAL LINKS
AEF Online
AF Portal
AF E-publishing
AF Fitness
AFRC Biographies
AFRC/JCC Message
ARMS/RIW/SivMPPF
E-Finance
LeaveWeb
My Pay

MISC LINKS
ANG CBTs

HQ RIO Home
Last Logon: 5/2/2016 4:27:39 PM

HQ RIO

HQ Individual Reservist Readiness & Integration Organization

QUICK LINKS
MY READINESS
HQ RIO WEBSITE
CONTACT DIRECTORY
INTEGRATION CELL
RESERVE PAY OFFICE
IMA TRAVEL
DEFENSE TRAVEL SYSTEM
AROWS-R
UTAPSwab
myPERS
FAQs

Leadership

Col Carolyn A. Stickell
Commander

CMSgt Dolores M. Colella
Superintendent

MSgt Wendy T. Barraza
First Sergeant

HQ RIO:
DSN: 847-3746
Comm: 720-847-3746

VISIT YOUR HQ RIO DETACHMENT ONLINE

To determine your servicing HQ RIO Detachment, visit the "My Readiness" link above, select "My Readiness Report" and Your detachment number will be listed in the "General Information" section.



- Select Volunteers tab to start search and application process

Volunteer Reserve System (VRS), has been revised to enhance usability for the Volunteer and Requisitioner. This newer version continues to provide service to Reserve/Guard members for short-term and funded assignment vacancies. Force Generation Center (FGC) has management control of VRS. Volunteers should address specific questions concerning the vacancy to the POC listed. Should you have questions regarding the process for VRS, please email the FGC/FGF FARS at afrc.fgc.far@us.af.mil.

Users will notice several new key features in this version, all designed to make the matching process more efficient. Volunteers can search for opportunities by a variety of factors (specific dates, ranks, AFSCs, locations, keywords). Volunteers can track application status within VRS. Supervisor permission is the first step in the application process. Emails to the volunteer are sent during the final steps of the application process to offer acceptance.

VRS is voluntary and Requisitioners are responsible to ensure each listing reflects a current requirement. In addition, Requisitioners are responsible for the validity and accuracy of each posting.

Training

- [Training Calendar](#)

Slide Decks

- [How to Volunteer](#)
- [How to be a Requisitioner](#)

Entitlements

- [Entitlements](#)

© 2016 - ARCNet Release Version 2.4 Branch3.5.0 CLR Image v4.0.30319 Build v2010.3.1317.0 Build Date 04/21/2016 14:01:13

[Privacy and Security Policy](#) [Contact ARCNet](#) [About](#) [Section 508 Statement](#) [Air Force Reserve](#)



- Volunteer menu view will search all available opportunities using the listed search options

Search

Searches This Session:

Job Id:

Keyword:
Separate keywords with a comma (,)

Job Source:
Select A Job Source...

Location:

AFSC:
Wildcard:

Grade:
Select A

Duration:
Select A

Search (ENTER) Clear Search Search Guide

Export to Excel Export to PDF

Drag a column header and drop it here to group by that column

Job	Title	AFSCa	Location	Report (NLT)	Duration	Desired Grade	
191400	Air Refueling Planner/Executor (copy)	011M4	Scott AFB Illinois United States USNORTHCOM	5/31/2016	180	0-4	Apply
191411	24 AF MPA Support	32E4	24AF Lackland AFB TX	6/29/2015	0	0-4	Apply



- To view additional information on vacancy click on “+” or “Job”
- Click “Apply” to start application process

The screenshot shows the ARCNet VRS application interface. At the top, there is a navigation bar with the ARCNet logo and various menu items: Home, Participation, Duty Plan, ATMT, Readiness, VRS, Member, Email, and Web Admin. The user is logged in as charnique.j.jones [cosmo].

The main content area features a search form with the following fields:

- Job Id:
- Keyword: (with a note: "Separate keywords with a comma (,)")
- Job Source:
- Location:
- AFSC: (with a note: "Wildcard: X")
- Grade:
- Duration:

Below the search form are buttons for "Search (ENTER)", "Clear Search", and "Search Guide".

Below the search form is a table of search results. The table has columns for Job, Title, AFSCs, Location, Report (NLT), Duration, and Desired Grade. There are also buttons for "Export to Excel" and "Export to PDF".

Job	Title	AFSCs	Location	Report (NLT)	Duration	Desired Grade	
192536	USSOCOM J1 Plans, Policy, and Programs Superintendent	3S071	MacDill AFB, FL	5/22/2016	120	E-8	Apply
192572	350 Personnel Tech	3S051	Robins AFB GA	5/21/2016	131	E-6	Apply

A blue arrow points to the "Apply" button for the first job listing.



- **After application is submitted it traverses the following process:**

The screenshot displays the ARCNet VRS application process interface. The browser address bar shows the URL: <https://www.my.af.mil/arcnet/Vrs/Volunteer/Apply/192536>. The page title is "ARCNet - Vrs Volunteer Ma...". The navigation menu includes: Home, Participation, Duty Plan, ATMT, Readiness, VRS, Member, Email, and Web Admin. The user is logged in as "charnique.j.jones (cosmo)".

The main content area is titled "TR Application Process (AFRC application process for TR members)". It features a table with the following columns: "Step in Application", "Point of Contact's Comments", and "Date and Time".

Step in Application	Point of Contact's Comments	Date and Time
Volunteer		
Supervisor Approval		
UDM Approval		
LRS Approval		
Wing CC Approval		
FAM Approval	CIV Elsie Houey	
FGC Approval	CIV Michael Carter	
Requisitioner Review	Col Brett Buras	

Below the table is an "Upload Files" section with a "Maximum Combined File Size: 9 MB" warning and a "Select files..." button.



Deployment Responsibilities

HQ RIO

Per AFI 36-3802

- Cut CED orders for **ALL** IR's
- Initiates AEF tasking in M4S
(Exception: Gaining MAJCOMs process M4S for exercise participation)
- Initiates Contingency Orders and AROWS-R (AROWS-R orders are Title 10 orders for IR's to be paid, CED orders are for travel to and from AOR)
- Updates DPDRT (Deployment Discrepancy System)
(Note: a discrepancy will count against the IR's tasking unit)

AD Unit

Per AFI 10-401

- Forecast 2 years in advance for MPA Money if considering using IR's for deployments
- Trains
- Equips- uniforms and equipment
- Schedules Pre-deployment training
- Schedules Transportation to AOR
- In and Out-Processing
- Provide reason for DPDRT Discrepancy
- Submits Delayed Report
- Submits the reclama when an IR is unable to fill a requirement



IMA Volunteer Process (phase 1)

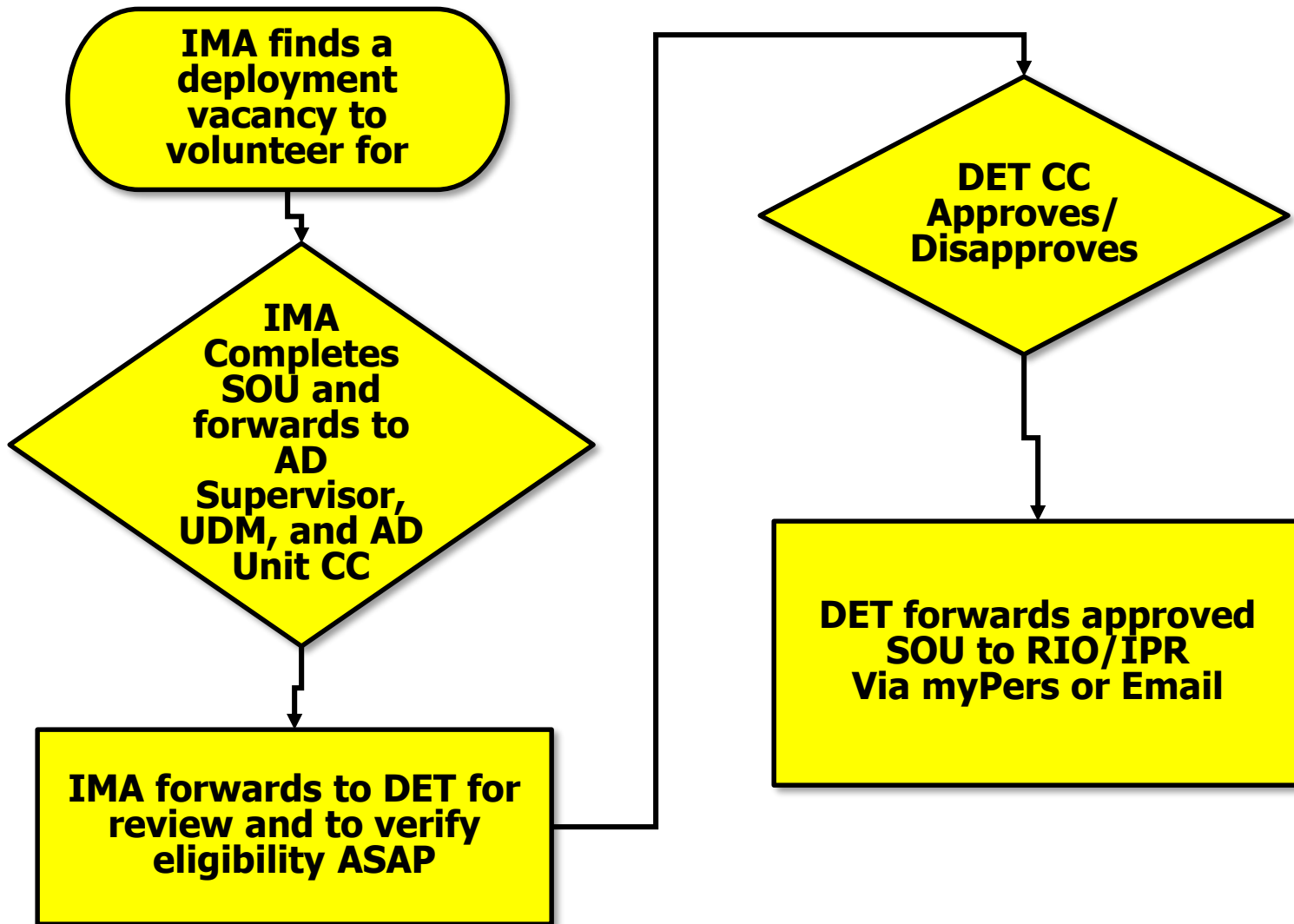



IMA Volunteer Process (phase 2)

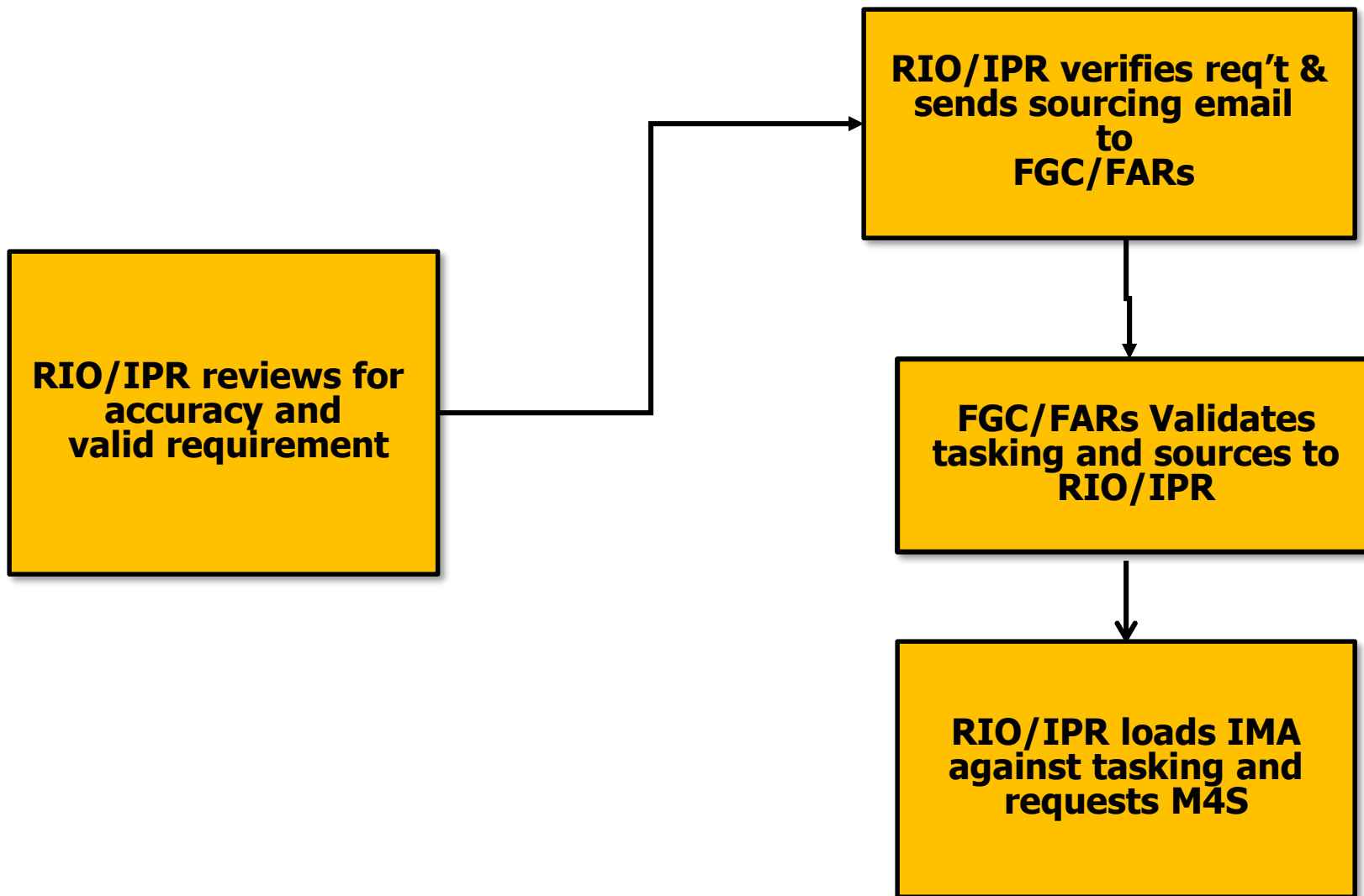



IMA Volunteer Process (phase 3)

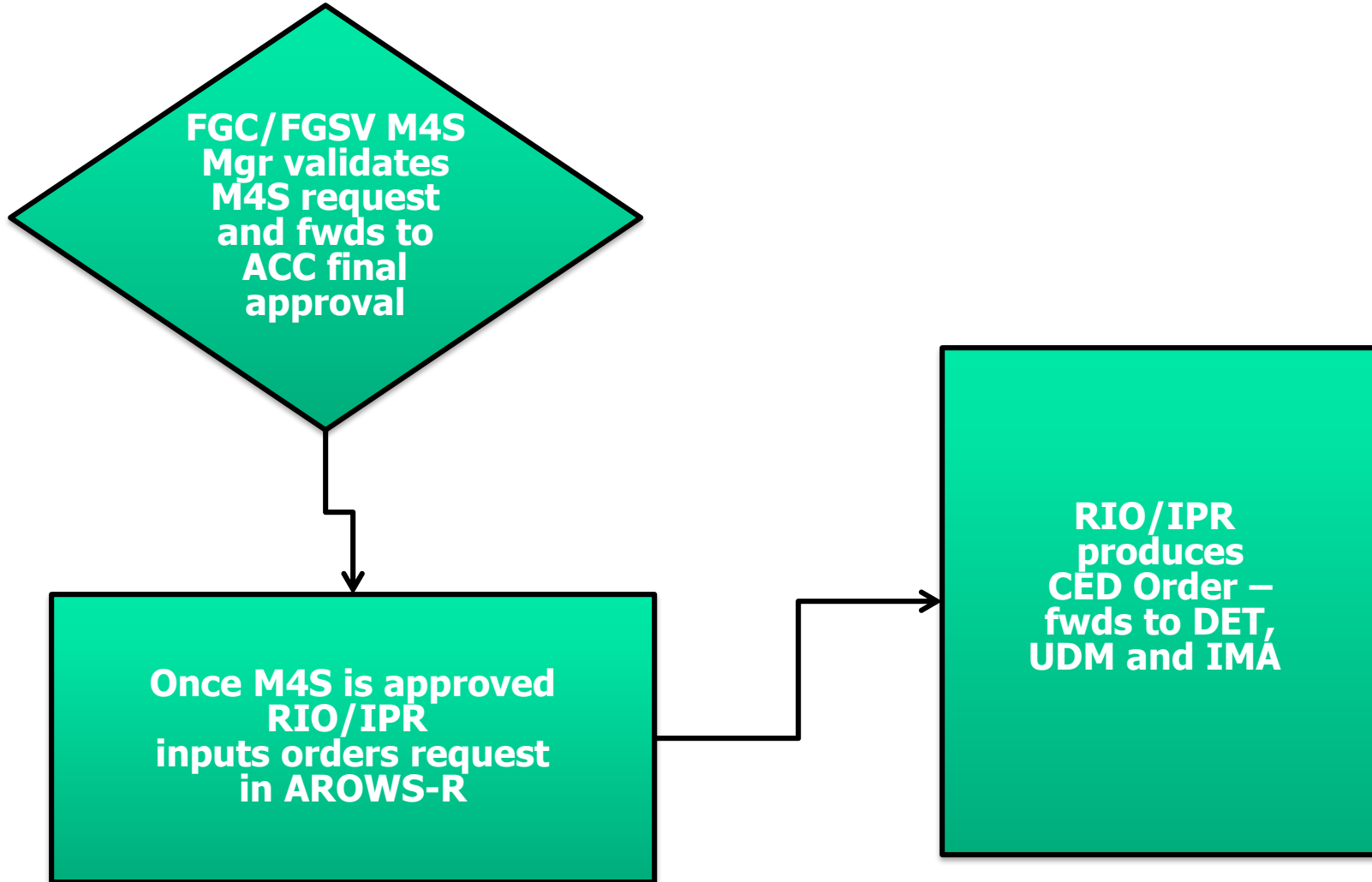



Statement of Understanding (SOU)

- All Deployment and Exercise requests require members to submit a Statement of Understanding (SOU) through their unit and supporting RIO Det which can be found at <http://www.arpc.afrc.af.mil/HQRIO/IMA-Deployments/>

IR Volunteer Statement of Understanding
AEF, Non-AEF (with ULN) and Exercise (with ULN)

DIRECTIONS:
Part I - Member completes
Part II - UDM/unit completes
Part III - Det/CC completes and emails completed package (SOU) to HQ RIO/IPR at arpc.ir@us.af.mil

IMPORTANT: IRs are not authorized to participate in active flying or flying training while deployed unless a waiver is approved IAW AFI 11-401 table 2.2 (HQ RIO/IR HARM)

PART I - MEMBER INFORMATION

Last _____ First _____ Middle _____ Rank _____ Social Security Number _____

Home Address (Before and During deployment) _____

Home Phone _____ Cell Phone _____ DSN Work Phone _____

Email address (both personal and work) _____

Attached Unit (where you perform duty) _____ Base and State _____ PAS Code _____

Duty AFSC _____

I am a volunteer to deploy in support of an Active Component requirement. I understand I must meet all IR readiness requirements before volunteering for this deployment, and that it is my responsibility to check my readiness level in ARCNET prior to my HQ RIO Detachment forwarding this request. I further understand that once I am assigned against a ULN for a specific deployment, that I am committed to that tasking. If I am unable to fill this requirement, I must notify my RegAE Commander who will be responsible for filling the tasking or submitting the reclama to AFPC/DPW. I must also notify my Detachment/CC and HQ RIO/IPR Staff. Initials _____

If selected for this deployment, I understand I may use any remaining IDT or annual four days to complete ancillary training requirements associated with deployment. Furthermore, I understand I must depart from and return to my unit of attachment provided above. I understand that I will be afforded 2.5 days downtime for every 30 days deployed up to a maximum of 14 days. I understand this downtime will be taken within the established commuting area of unit of assignment, all in-processing activities will be completed during this time per current AFRC/CV Downtime policy. I understand the 14 days start immediately upon my return to U.S. Leave time is a separate entitlement. I acknowledge upon signing this SOU that I have read and understand Part I and will comply with all pre-deployment training requirements to include ancillary training prior to deployment. Initials _____

ULN DRIVEN EXERCISE (Initial if this is an exercise ULN)
If selected for an ULN driven exercise, I understand I may NOT use any remaining IDTs to participate in the exercise. Furthermore, I understand if I participate in an ULN driven exercise in IDT status I will pay my travel and per diem out of pocket. Unless exercise is at unit of assignment and member is in place, I will be departing from home station or home of residence for this exercise. Initial _____

SOU - Mar, 2018 Page 1

This information is subject to the Privacy Act of 1974. This information is not to be disclosed without the authorization of the individual(s), and is to be used For Official Use Only. Violations of the Privacy Act are subject to fines of \$5,000 or 2 years in prison.

IR Signature _____ Date _____

IMPORTANT: IRs are not authorized to participate in active flying or flying training while deployed unless a waiver is approved IAW AFI 11-401 table 2.2 (HQ RIO/IR HARM)

PART II - UNIT OF ATTACHMENT & COMMANDER'S CERTIFICATION
IMPORTANT: IMAs are not authorized to participate in active flying or flying training while deployed.

AEF (HQ RIO/IPR requests MPA only) Non-AEF w/ULN Exercise w/ULN _____ (Name of exercise)

ULN/Line Number: _____
Location: OCONUS CENTCOM AOR OCONUS CONUS

Status for Exercises only: IDT Annual Tour RPA MPA MAS Tasking # _____

Pre-Deployment Training Start Date/Location: _____

*Note Please list all training required for the tasking to include the location. All training has to be line remark driven or added as an ILOC.

Supervisor:
I Concur/Non-Concur with this deployment request. (Circle One)

Sign and Print Name, Grade, Unit, DSN _____ Date _____ Supervisor Email Address _____

Unit Deployment Manager (UDM):
I certify this member meets all requirements associated with requested ULN. I understand if the AD unit commander approves the individual to deploy it is my responsibility to train and equip them for deployment IAW AFI 10-401 para 11.18.2.10, AFI 36-2629, and CDR reporting instructions and requirement line remarks. I will request RDD change or delayed reporting if this request is submitted within 30 days of known First Movement to allow 30 days for IR deployment processing. I understand it is the responsibility of my unit to fill the tasking or submit reclama (if originally tasked unit) to AFPC/DPW (AEF requirements only) if the IR member for whatever reason does not fill the AEF deployment. If we are not the originally tasked unit, HQ RIO/IPR will have the tasking sourced back to them for filling or reclama action. I understand HQ RIO/IPR will take all necessary actions within DCAPEs and generate all orders related to this tasking.

Sign and Print Name, Grade, Unit, DSN _____ Date _____ UDM Email Address _____

AD FSS/IPR
I certify IAW AFI 36-3802 Attachment 2: I will in/out process IRs who are deployed for direct or indirect support of a contingency operation. I understand that all IRs CED orders will be cut and processed by HQ RIO/IPR and a copy of the order will be emailed to AD FSS/IPR. Furthermore, I understand I will not for any reason cut CED orders on IR members and once ULN is sourced to 96 TPAS I will have no visibility of tasking in DCAPEs.

SOU - Mar, 2018 Page 2

This information is subject to the Privacy Act of 1974. This information is not to be disclosed without the authorization of the individual(s), and is to be used For Official Use Only. Violations of the Privacy Act are subject to fines of \$5,000 or 2 years in prison.



Involuntary Activations

- **All members of the SelRes are subject to mobilization per AFI 10-401 and AFI 10-402**
 - **Discuss vulnerability windows with your AFRC FAM**
 - **Proactively identify any deployment-limiting conditions**
- **Requirements for involuntary activations are submitted to AFRC and then sourced by the AFRC FAM**
- **Mobilization packages require GO concurrence from IMAs command of assignment**
- **Once tasked, members are INELIGIBLE for any other personnel actions (i.e. retirement, IRR transfer)**
- **Volunteers can be substituted in place of non-vols**
 - **Original member remains frozen until vol deploys**



Deployment Waivers

- **1095—A waiver is required for participation exceeding 1095 days in a rolling 4-year window**
 - **If greater than 1095 but less than 1400 & does not cross fiscal years = AFRC & ACC CV approval required**
 - **If greater than 1400 and/or crosses fiscal years = SAF/MR approval required**
 - **1095 waivers are not required for 12302 and 12304(b)**
- **Per Diem—Any TDY greater than 180 days automatically results in a PCS without PCA; members will receive local BAH entitlements vs per diem**



- **All IMAs must have an AEF Indicator entered into MilPDS per AFI 10-401**
 - **All IRs should have an AEFI code assigned in MILPDS by their assigned active duty unit which should correspond to their unit's AEF vulnerability period. i.e. X1, X2 etc. (Note: IRs assigned to those organizations can be tasked only through mobilization or volunteer process).**



U.S. AIR FORCE

Questions?